

VIPA System SLIO

IM | 053-1DN00 | Manual

HB300 | IM | 053-1DN00 | GB | 14-11

VIPA GmbH
Ohmstr. 4
91074 Herzogenaurach
Telephone: +49 9132 744-0
Fax: +49 9132 744-1864
email: info@vipa.com
Internet: www.vipa.com

Table of contents

1	General	4
1.1	Copyright © VIPA GmbH	4
1.2	About this manual.....	5
1.3	Safety information.....	6
2	Basics and Assembly	8
2.1	Safety Information for Users.....	8
2.2	System conception.....	9
2.3	Dimensions.....	12
2.4	Installation.....	13
2.5	Demounting and module exchange.....	18
2.6	Wiring.....	22
2.7	Trouble shooting - LEDs.....	26
2.8	Installation guidelines.....	26
2.9	General data.....	29
3	Hardware description	31
3.1	Properties.....	31
3.2	Structure.....	32
3.2.1	Interfaces.....	32
3.2.2	Address switch.....	33
3.2.3	LEDs.....	35
3.3	Technical Data.....	36
4	Deployment	38
4.1	Basics DeviceNet.....	38
4.2	Accessing the System SLIO.....	39
4.2.1	Accessing the I/O area.....	41
4.2.2	Accessing parameter data.....	42
4.2.3	Accessing diagnostics data.....	43
4.3	Transfer rate and DeviceNet address.....	44
4.3.1	Setting the transfer rate	44
4.3.2	Setting the DeviceNet address.....	45
4.4	Status indication - Diagnostics.....	46

1 General

1.1 Copyright © VIPA GmbH

All Rights Reserved

This document contains proprietary information of VIPA and is not to be disclosed or used except in accordance with applicable agreements.

This material is protected by the copyright laws. It may not be reproduced, distributed, or altered in any fashion by any entity (either internal or external to VIPA), except in accordance with applicable agreements, contracts or licensing, without the express written consent of VIPA and the business management owner of the material.

For permission to reproduce or distribute, please contact: VIPA, Gesellschaft für Visualisierung und Prozessautomatisierung mbH Ohmstraße 4, D-91074 Herzogenaurach, Germany

Tel.: +49 9132 744 -0

Fax.: +49 9132 744-1864

E-Mail: info@vipa.de

<http://www.vipa.com>



Every effort has been made to ensure that the information contained in this document was complete and accurate at the time of publishing. Nevertheless, the authors retain the right to modify the information.

This customer document describes all the hardware units and functions known at the present time. Descriptions may be included for units which are not present at the customer site. The exact scope of delivery is described in the respective purchase contract.

CE Conformity Declaration

Hereby, VIPA GmbH declares that the products and systems are in compliance with the essential requirements and other relevant provisions. Conformity is indicated by the CE marking affixed to the product.

Conformity Information

For more information regarding CE marking and Declaration of Conformity (DoC), please contact your local VIPA customer service organization.

Trademarks

VIPA, SLIO, System 100V, System 200V, System 300V, System 300S, System 400V, System 500S and Commander Compact are registered trademarks of VIPA Gesellschaft für Visualisierung und Prozessautomatisierung mbH.

SPEED7 is a registered trademark of profichip GmbH.

SIMATIC, STEP, SINEC, TIA Portal, S7-300 and S7-400 are registered trademarks of Siemens AG.

Microsoft and Windows are registered trademarks of Microsoft Inc., USA.

Portable Document Format (PDF) and Postscript are registered trademarks of Adobe Systems, Inc.

All other trademarks, logos and service or product marks specified herein are owned by their respective companies.

Information product support

Contact your local VIPA Customer Service Organization representative if you wish to report errors or questions regarding the contents of this document. If you are unable to locate a customer service centre, contact VIPA as follows:

VIPA GmbH, Ohmstraße 4, 91074 Herzogenaurach, Germany

Telefax: +49 9132 744-1204

E-Mail: documentation@vipa.de

Technical support

Contact your local VIPA Customer Service Organization representative if you encounter problems with the product or have questions regarding the product. If you are unable to locate a customer service centre, contact VIPA as follows:

VIPA GmbH, Ohmstraße 4, 91074 Herzogenaurach, Germany

Tel.: +49 9132 744-1150 (Hotline)

E-Mail: support@vipa.de

1.2 About this manual**Objective and contents**

This manual describes the IM 053-1DN00 of the System SLIO from VIPA. It contains a description of the structure, project engineering and deployment. This manual is part of the documentation package with order number VIPA HB300E_IM and relevant for:

Product	Order number	as of state:	
		HW	FW
IM 053DN	053-1DN00	01	V1.2.5

Target audience

The manual is targeted at users who have a background in automation technology.

Structure of the manual

The manual consists of chapters. Every chapter provides a self-contained description of a specific topic.

- Guide to the document** The following guides are available in the manual:
- An overall table of contents at the beginning of the manual
 - References with page numbers
- Availability** The manual is available in:
- printed form, on paper
 - in electronic form as PDF-file (Adobe Acrobat Reader)
- Icons Headings** Important passages in the text are highlighted by following icons and headings:

**DANGER!**

Immediate or likely danger. Personal injury is possible.

**CAUTION!**

Damages to property is likely if these warnings are not heeded.



Supplementary information and useful tips.

1.3 Safety information

Applications conforming with specifications

The System SLIO is constructed and produced for:

- communication and process control
- general control and automation applications
- industrial applications
- operation within the environmental conditions specified in the technical data
- installation into a cubicle

**DANGER!**

This device is not certified for applications in
– in explosive environments (EX-zone)

Documentation

The manual must be available to all personnel in the

- project design department
- installation department
- commissioning
- operation

**CAUTION!**

The following conditions must be met before using or commissioning the components described in this manual:

- Hardware modifications to the process control system should only be carried out when the system has been disconnected from power!
- Installation and hardware modifications only by properly trained personnel.
- The national rules and regulations of the respective country must be satisfied (installation, safety, EMC ...)

Disposal

National rules and regulations apply to the disposal of the unit!

2 Basics and Assembly

2.1 Safety Information for Users

Handling of electrostatic sensitive modules

VIPA modules make use of highly integrated components in MOS-Technology. These components are extremely sensitive to over-voltages that can occur during electrostatic discharges. The following symbol is attached to modules that can be destroyed by electrostatic discharges.



The Symbol is located on the module, the module rack or on packing material and it indicates the presence of electrostatic sensitive equipment. It is possible that electrostatic sensitive equipment is destroyed by energies and voltages that are far less than the human threshold of perception. These voltages can occur where persons do not discharge themselves before handling electrostatic sensitive modules and they can damage components thereby, causing the module to become inoperable or unusable. Modules that have been damaged by electrostatic discharges can fail after a temperature change, mechanical shock or changes in the electrical load. Only the consequent implementation of protection devices and meticulous attention to the applicable rules and regulations for handling the respective equipment can prevent failures of electrostatic sensitive modules.

Shipping of modules

Modules must be shipped in the original packing material.

Measurements and alterations on electrostatic sensitive modules

When you are conducting measurements on electrostatic sensitive modules you should take the following precautions:

- Floating instruments must be discharged before use.
- Instruments must be grounded.

Modifying electrostatic sensitive modules you should only use soldering irons with grounded tips.



CAUTION!

Personnel and instruments should be grounded when working on electrostatic sensitive modules.

2.2 System conception

Overview

System SLIO is a modular automation system for assembly on a 35mm mounting rail. By means of the peripheral modules with 2, 4 or 8 channels this system may properly be adapted matching to your automation tasks. The wiring complexity is low, because the supply of the DC 24V power section is integrated to the backplane bus and defective modules may be replaced with standing wiring. By deployment of the power modules in contrasting colours within the system, further isolated areas may be defined for the DC 24V power section supply, respectively the electronic power supply may be extended with 2A.

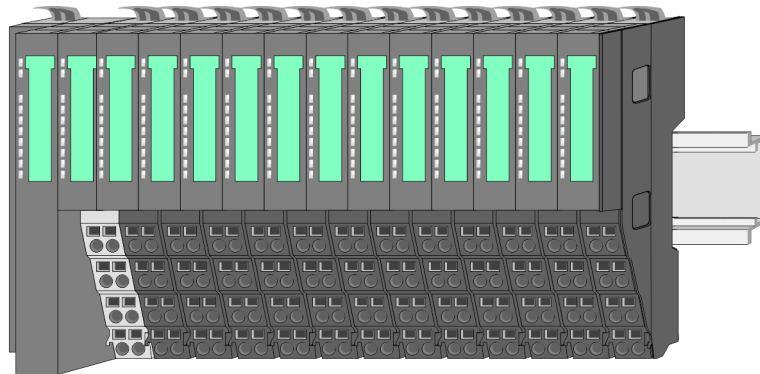

Components

- CPU (head module)
- Bus coupler (head module)
- Periphery modules
- Power modules
- Accessories



CAUTION!

Only modules of VIPA may be combined. A mixed operation with third-party modules is not allowed!

CPU



With a CPU, CPU electronic and power module are integrated to one casing. As head module via the integrated power module for power supply the CPU electronic is supplied as well as the electronic of the connected periphery modules. The DC 24 power section supply for the linked periphery modules is established via a further connection at the power module. By installing of up to 64 periphery modules at the CPU, these are electrically connected, this means these are assigned to the backplane bus, the electronic modules are power supplied and each periphery module is connected to the DC 24V power section supply.



CAUTION!

CPU part and power module of a CPU may not be separated! Here you may only exchange the electronic module!

Bus coupler

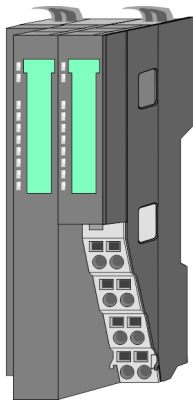

With a bus coupler bus interface and power module are integrated to one casing. With the bus interface you get access to a subordinated bus system. As head module via the integrated power module for power supply the bus interface is supplied as well as the electronic of the connected periphery modules. The DC 24 power section supply for the linked periphery modules is established via a further connection at the power module. By installing of up to 64 periphery modules at the bus coupler, these are electrically connected, this means these are assigned to the backplane bus, the electronic modules are power supplied and each periphery module is connected to the DC 24V power section supply.



CAUTION!

Bus interface and power module of the bus coupler may not be separated! Here you may only exchange the electronic module!

Periphery modules

Each periphery module consists of a *terminal* and an *electronic module*.

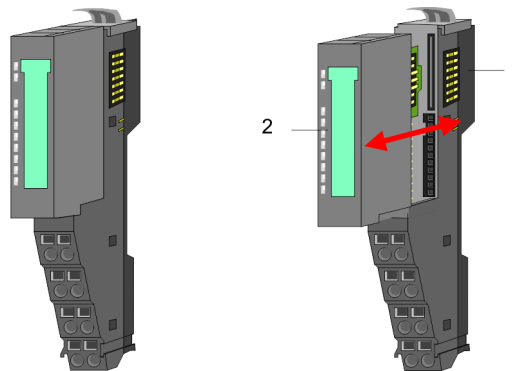

- 1 Terminal module
- 2 Electronic module

Terminal module

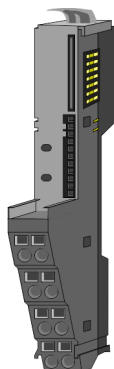

The *terminal module* serves to carry the electronic module, contains the backplane bus with power supply for the electronic, the DC 24V power section supply and the staircase-shaped terminal for wiring. Additionally the terminal module has a locking system for fixing at a mounting rail. By means of this locking system your SLIO system may be assembled outside of your switchgear cabinet to be later mounted there as whole system.

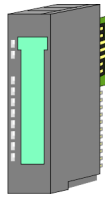
Electronic module

The functionality of a SLIO peripheral module is defined by the *electronic module*, which is mounted to the terminal module by a safe sliding mechanism. With an error the defective module may be exchanged for a functional module with standing installation.

At the front side there are LEDs for status indication. For simple wiring each module shows a corresponding connection diagram at the front and at the side.

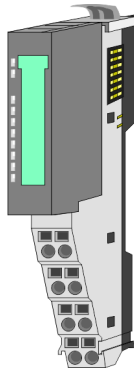
Power module

In the System SLIO the power supply is established by power modules. These are either integrated to the bus coupler or may be installed between the peripheral modules. Depending on the power module isolated areas of the DC 24V power section supply may be defined respectively the electronic power supply may be extended with 2A. For better recognition the colour of the power modules are contrasting to the periphery modules.

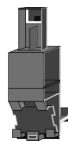
Accessories**Shield bus carrier**

The shield bus carrier (order no. 000-0AB00) serves to carry the shield bus (10mm x 3mm) to connect cable shields. Shield bus carriers, shield bus and shield fixings are not in the scope of delivery. They are only available as accessories.

The shield bus carrier is mounted underneath the terminal of the terminal module. With a flat mounting rail for adaption to a flat mounting rail you may remove the spacer of the shield bus carrier.

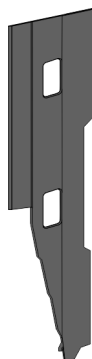
Bus cover

With each bus coupler, to protect the backplane bus connectors, there is a mounted bus cover in the scope of delivery. You have to remove the bus cover of the bus coupler before mounting a SLIO module. For the protection of the backplane bus connector you always have to mount the bus cover at the last module of your system again.

The bus cover has the order no. 000-0AA00.

Coding pins



There is the possibility to fix the assignment of electronic and terminal module. Here coding pins (order number 000-0AC00) from VIPA can be used.

The coding pin consists of a coding jack and a coding plug. By combining electronic and terminal module with coding pin, the coding jack remains in the electronic module and the coding plug in the terminal module.

This ensures that after replacing the electronics module just another electronic module can be plugged with the same encoding.

2.3 Dimensions

Dimensions CPU

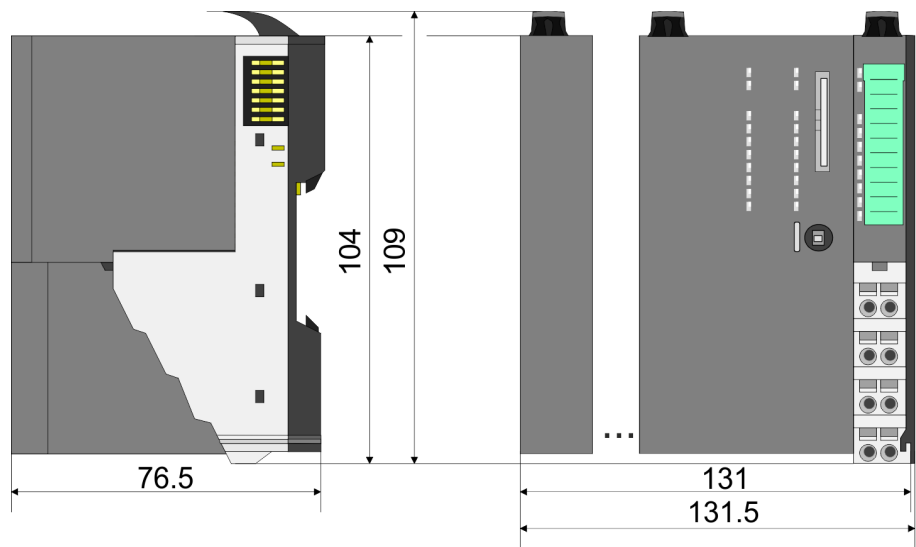

Dimensions bus coupler

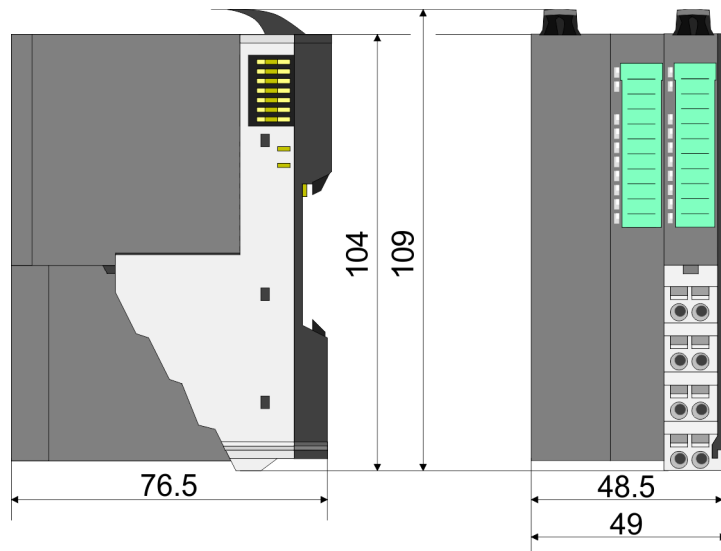

Dimensions periphery module

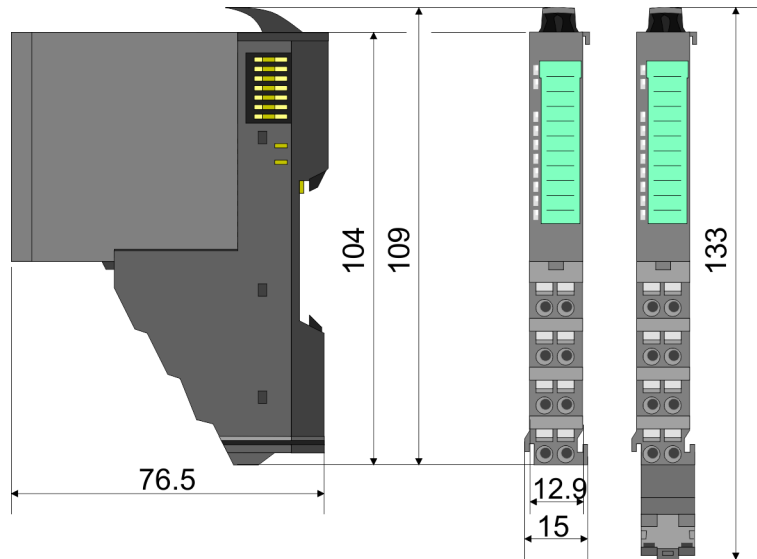

Dimensions electronic module

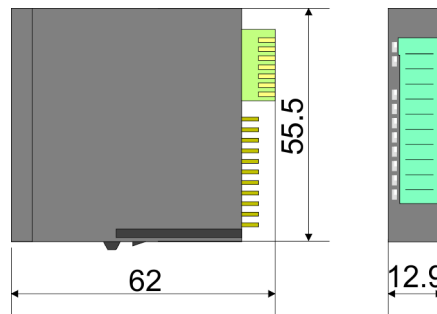

Dimensions in mm

2.4 Installation

Functional principle

There is a locking lever at the top side of the terminal module. For mounting and demounting this locking lever is to be turned upwards until this engages audible. Now the module may be pulled forward. For mounting plug the module to the module installed before and push the module to the mounting rail guided by the strips at the upper and lower side of the module. The module is fixed to the mounting rail by pushing downward the locking lever. The modules may either separately be mounted to the mounting rail or as block. Here is to be considered that each locking lever is opened.

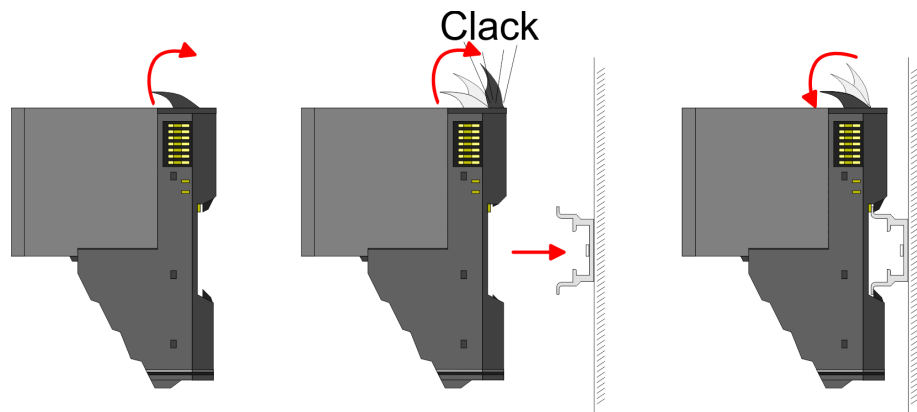

For the exchange of a electronic module, the electronic module may be pulled forward after pressing the unlocking lever at the lower side of the module. For installation plug the electronic module guided by the strips at the lower side until this engages audible to the terminal module.

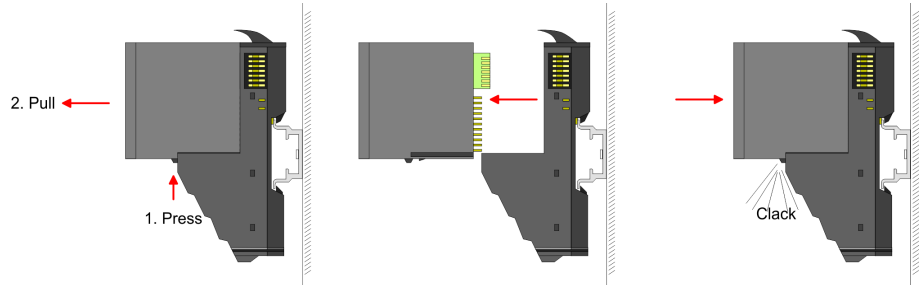

Coding



There is the possibility to fix the assignment of electronic and terminal module. Here coding pins (order number 000-0AC00) from VIPA can be used. The coding pin consists of a coding jack and a coding plug. By combining electronic and terminal module with coding pin, the coding jack remains in the electronic module and the coding plug in the terminal module. This ensures that after replacing the electronics module just another electronic module can be plugged with the same encoding.

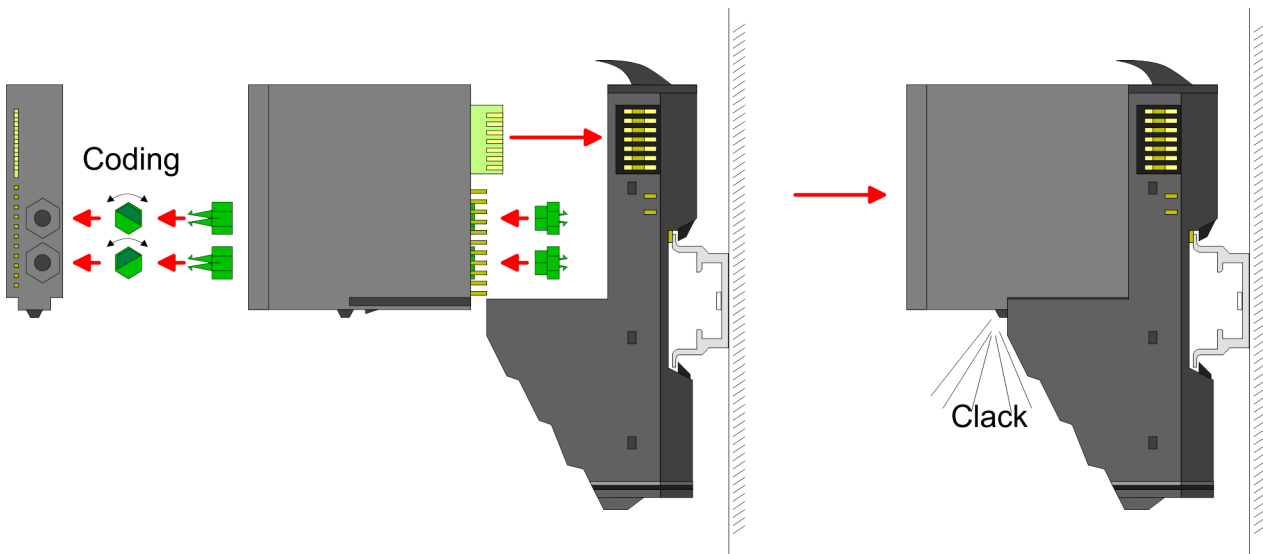

Each electronic module has on its back 2 coding sockets for coding jacks. Due to the characteristics, with the coding jack 6 different positions can be plugged, each. Thus there are 36 possible combinations for coding with the use of both coding sockets.

1. ► Plug, according to your coding, 2 coding jacks in the coding sockets of your electronic module until they lock.
2. ► Now plug the according coding plugs into the coding jacks.
3. ► To fix the coding put both the electronic and terminal module together until they lock.

**CAUTION!**

Please consider that when replacing an already coded electronic module, this is always be replaced by an electronic module with the same coding.

Even with an existing coding on the terminal module, you can plug an electronic module without coding. The user is responsible for the correct usage of the coding pins. VIPA assumes no liability for incorrectly attached electronic modules or for damages which arise due to incorrect coding!

Mounting Proceeding

The modules were directly be mounted to the mounting rail and so connected to the backplane bus and the power supply for the electronic and power section. Up to 64 modules may be mounted. Please consider here that the sum current of the electronic power supply does not exceed the maximum value of 3A. By means of the power module 007-1AB10 the current of the electronic power supply may be expanded with 2A. ↪ *Chapter 2.6 'Wiring' on page 22*

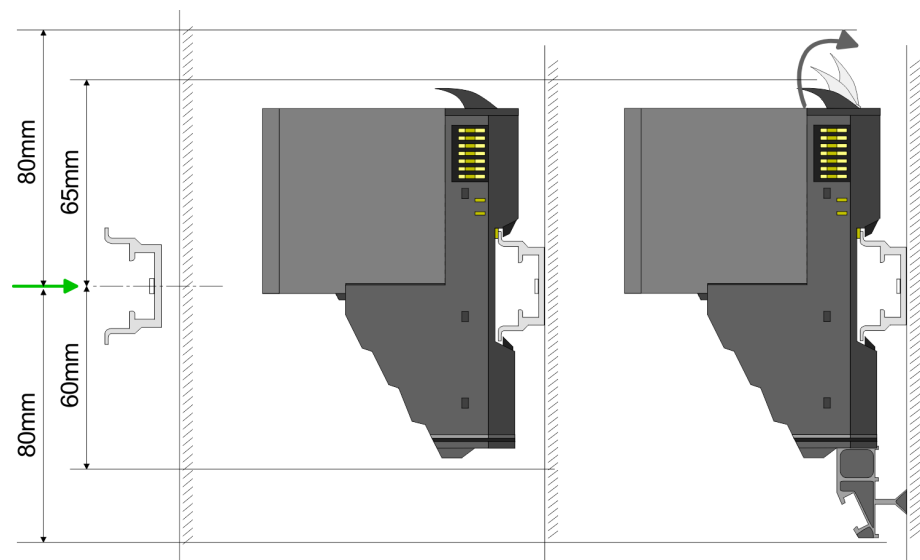
Mounting rail

- ➔ Mount the mounting rail! Please consider that a clearance from the middle of the mounting rail of at least 80mm above and 60mm below, respectively 80mm by deployment of shield bus carriers, exist.

Mounting Head module (e.g. bus coupler)

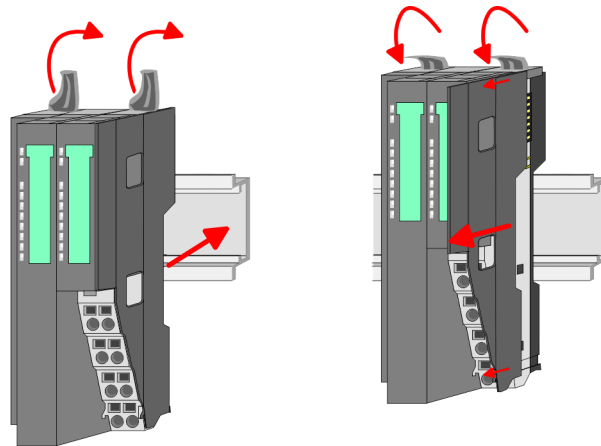

1. ▶ Start at the left side with the head module (e.g. bus coupler). For this turn both locking lever upwards, put the head module to the mounting rail and turn both locking lever downward.
2. ▶ Before mounting the periphery modules you have to remove the bus cover at the right side of the Head module by pulling it forward. Keep the cover for later mounting.

Mounting periphery modules

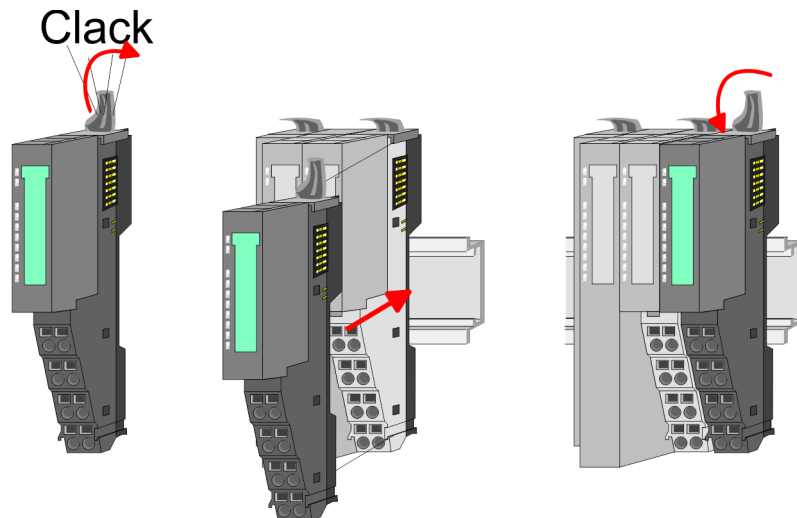

- ▶ Mount the periphery modules you want.

Mounting the bus cover

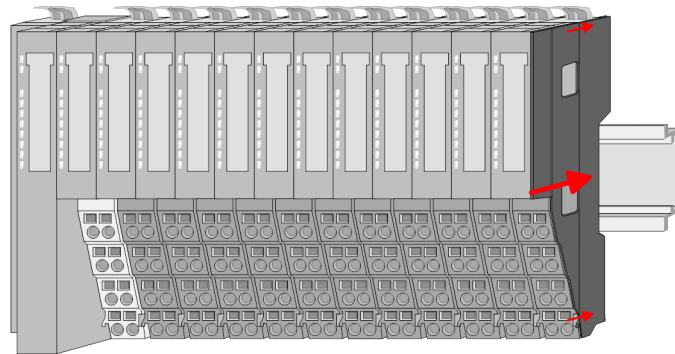

- ➔ After mounting the whole system, to protect the backplane bus connectors at the last module you have to mount the bus cover, now.

Mounting the bus cover at a clamp module

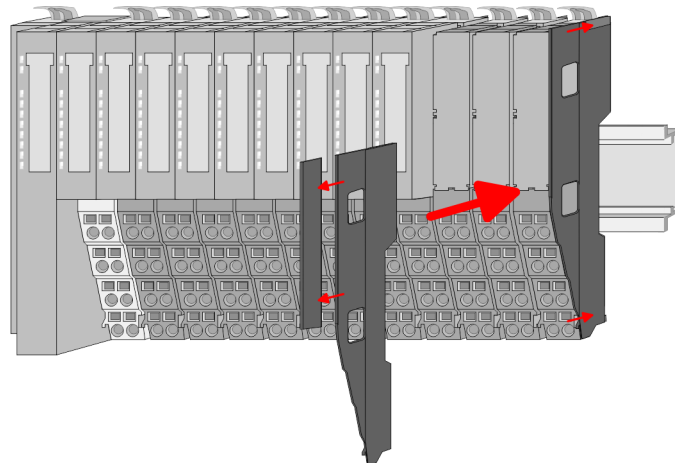

- ➔ If the last module is a clamp module, for adaptation the upper part of the bus cover is to be removed

Mounting shield bus carrier

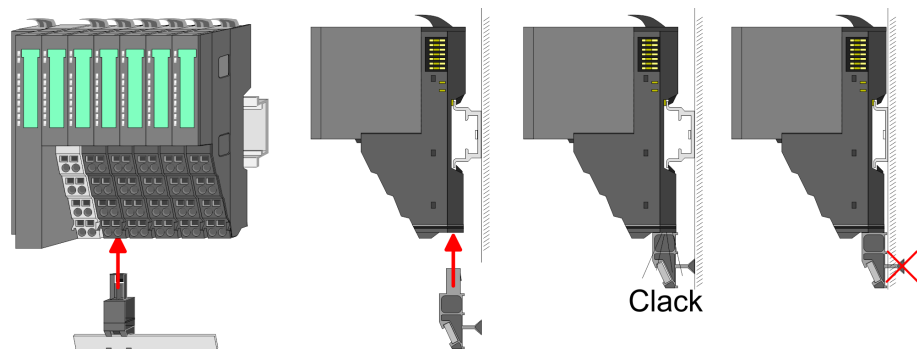

- ➔ The shield bus carrier (available as accessory) serves to carry the shield bus to connect cable shields. The shield bus carrier is mounted underneath the terminal of the terminal module. With a flat mounting rail for adaption to a flat mounting rail you may remove the spacer of the shield bus carrier.

2.5 Demounting and module exchange

Proceeding

With demounting and exchange of a module, head module (e.g. bus coupler) or a group of modules for mounting reasons you have always to remove the electronic module of the just mounted right module. After the mounting it may be plugged again.

Exchange of an electronic module

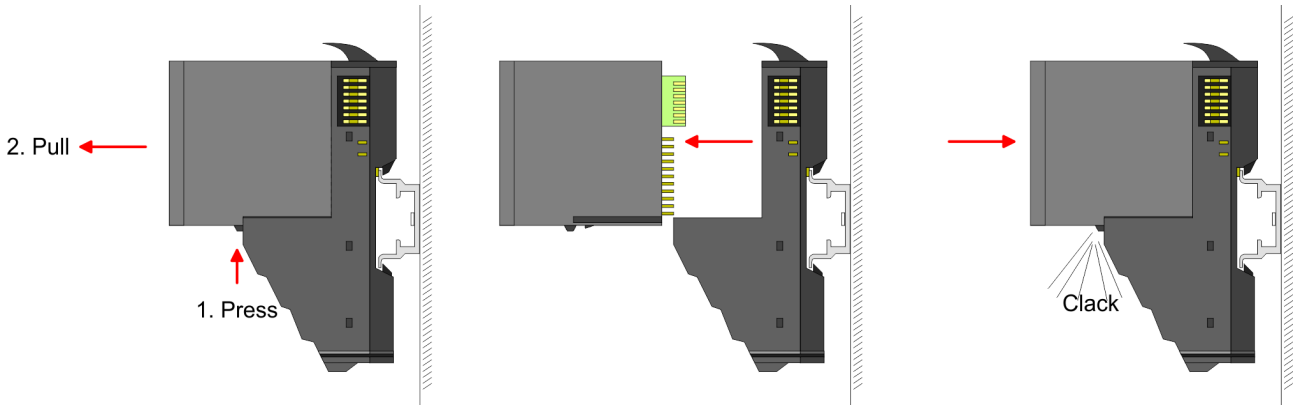

1. ➤ For the exchange of an electronic module, the electronic module may be pulled forward after pressing the unlocking lever at the lower side of the module.
2. ➤ For installation plug the electronic module guided by the strips at the lower side until this engages audible to the terminal module.

Exchange of a module

1. ➤ Remove if exists the wiring. ↪ *Chapter 2.6 'Wiring' on page 22.*

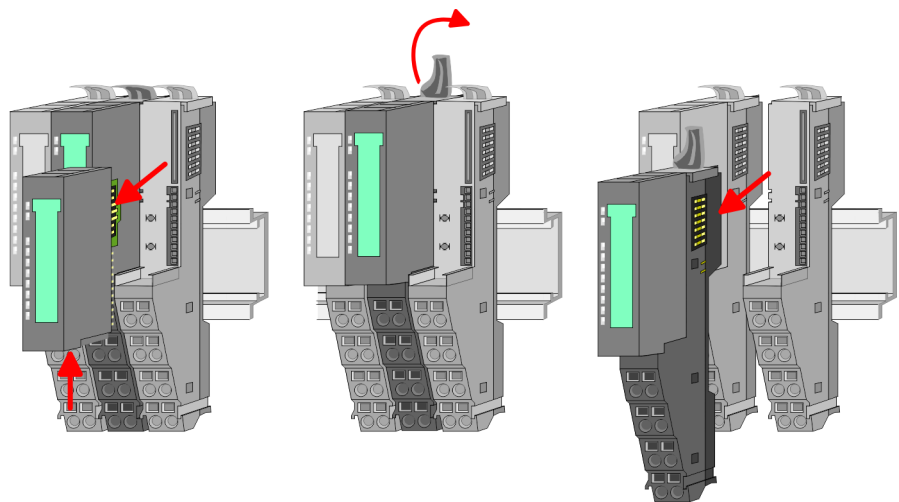

2. ➤ Press the unlocking lever at the lower side of the just mounted right module and pull it forward.
3. ➤ Turn the locking lever of the module to be exchanged upwards.
4. ➤ Pull the module forward.

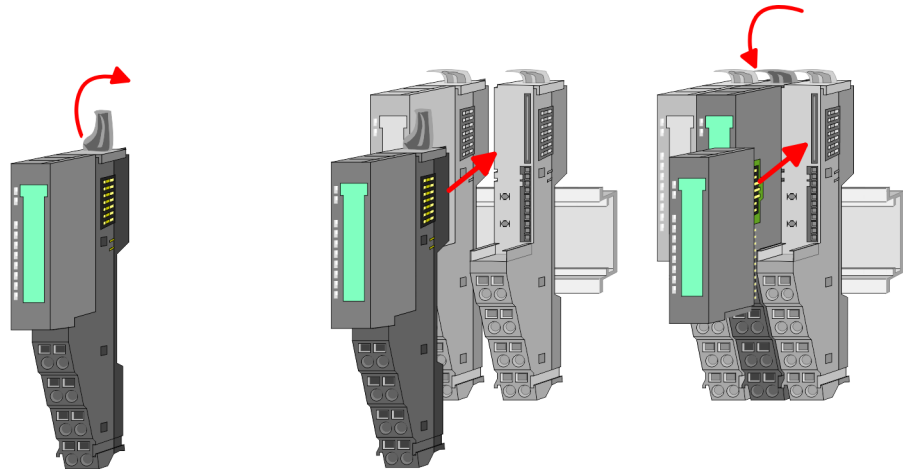

5. ▶ For mounting turn the locking lever of the module to be mounted upwards.
6. ▶ To mount the module put it to the gap between the both modules and push it, guided by the stripes at both sides, to the mounting rail.
7. ▶ Turn the locking lever downward again.
8. ▶ Plug again the electronic module, which you have removed before.

Exchange of a head module (e.g. bus coupler)



CAUTION!

Bus interface and power module of a head module may not be separated!

Here you may only exchange the electronic module!

1. ▶ Remove if exists the wiring of the head module. ↪ *Chapter 2.6 'Wiring' on page 22.*

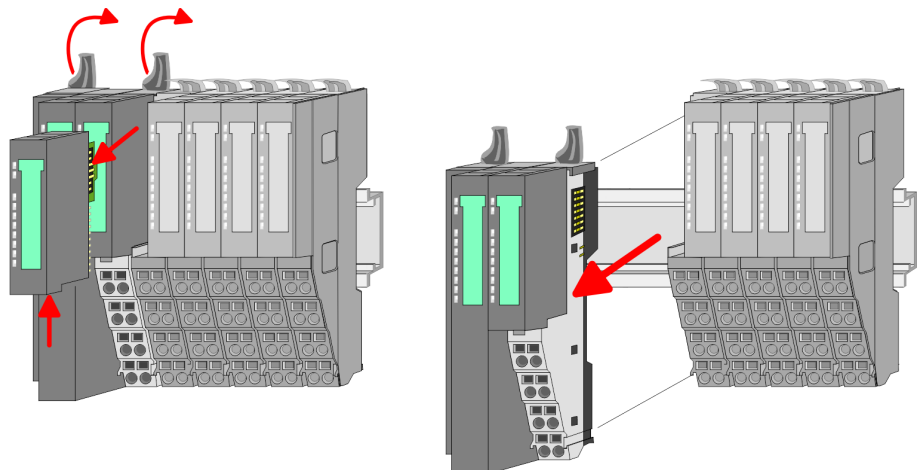

2. ▶ Press the unlocking lever at the lower side of the just mounted right module and pull it forward.
3. ▶ Turn all the locking lever of the head module to be exchanged upwards.
4. ▶ Pull the head module forward.

Demounting and module exchange

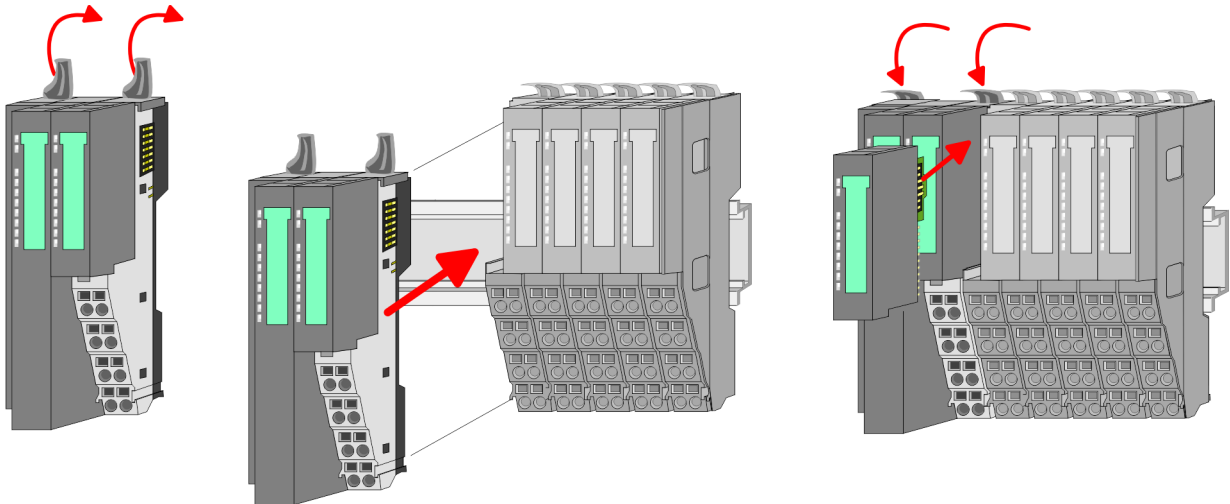

5. ▶ For mounting turn all the locking lever of the head module to be mounted upwards.
6. ▶ To mount the head module put it to the left module and push it, guided by the stripes, to the mounting rail.
7. ▶ Turn all the locking lever downward again.
8. ▶ Plug again the electronic module, which you have removed before.

Exchange of a module group

1. ▶ Remove if exists the wiring of the module group. ↪ *Chapter 2.6 'Wiring' on page 22.*

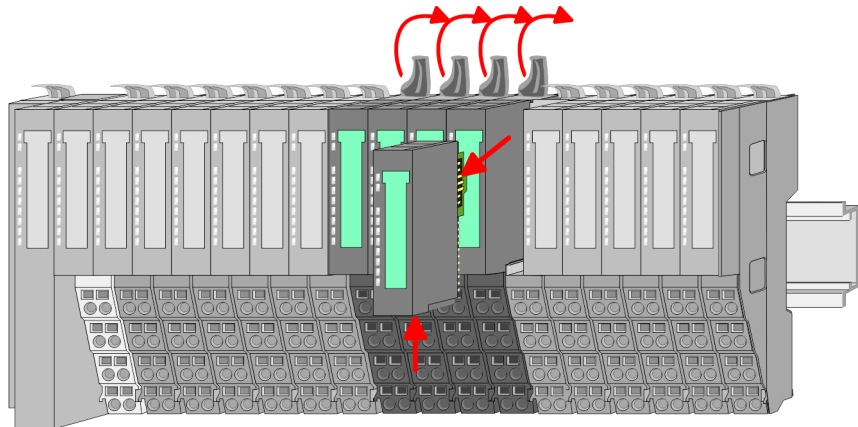

2. ▶ Press the unlocking lever at the lower side of the just mounted right module of the module group and pull it forward.

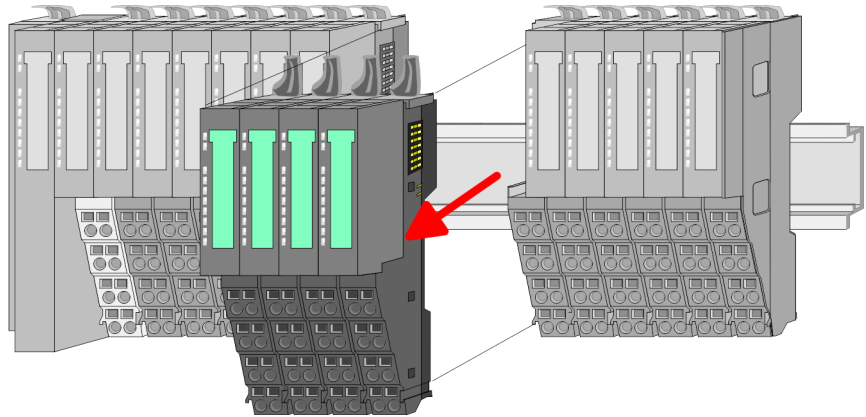

3. Turn all the locking lever of the module group to be exchanged upwards.
4. Pull the module group forward.

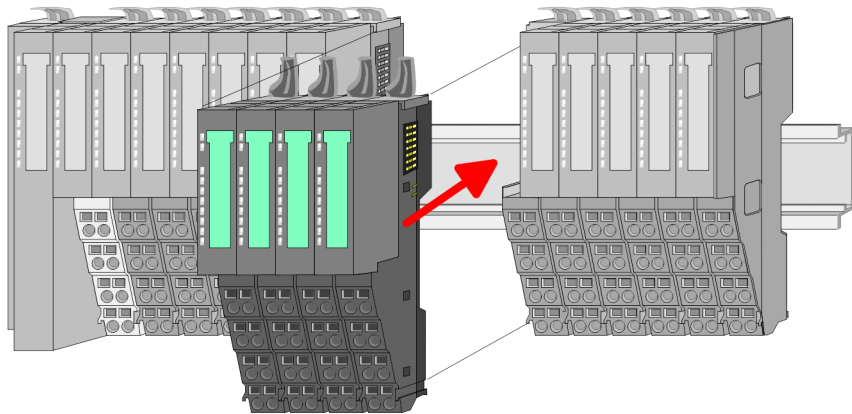
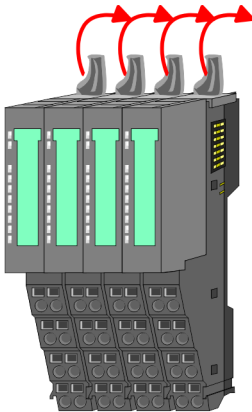

5. For mounting turn all the locking lever of the module group to be mounted upwards.
6. To mount the module group put it to the gap between the both modules and push it, guided by the stripes at both sides, to the mounting rail.

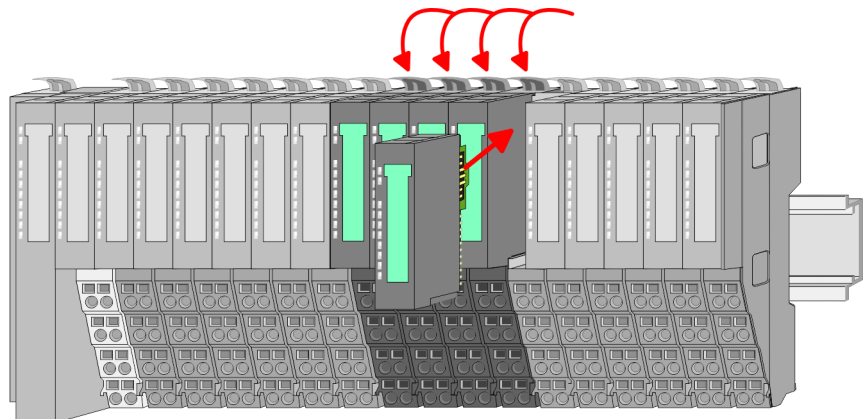

7. Turn all the locking lever downward again.
8. Plug again the electronic module, which you have removed before.

2.6 Wiring

Connectors

Terminals with spring clamp technology are used for wiring.

The spring clamp technology allows quick and easy connection of your signal and supply lines.

In contrast to screw terminal connections this type of connection is vibration proof.

Data

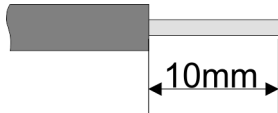

U_{max} : 240V AC / 30V DC

I_{max} : 10A

Cross section: 0.08 ... 1.5mm² (AWG 28 ... 16)

Stripping length: 10mm

Wiring procedure

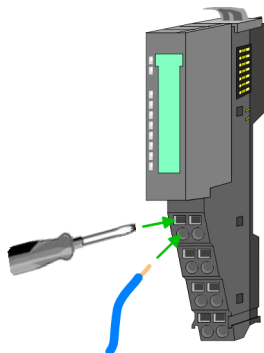
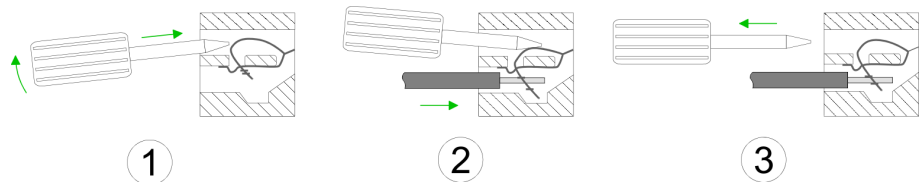

1. ➤ Insert a suited screwdriver at an angle into the square opening as shown. Press and hold the screwdriver in the opposite direction to open the contact spring.
2. ➤ Insert the stripped end of wire into the round opening. You can use wires with a cross section of 0.08mm² to 1.5mm².
3. ➤ By removing the screwdriver, the wire is securely fixed via the spring contact to the terminal.

Standard wiring

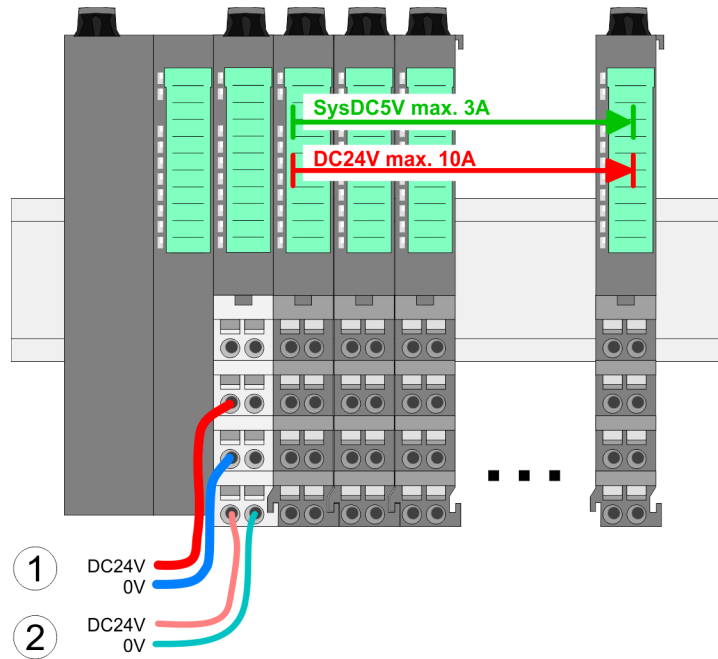

- (1) DC 24V for power section supply I/O area (max 10A)
- (2) DC 24V for electronic power supply bus coupler and I/O area

PM - Power module

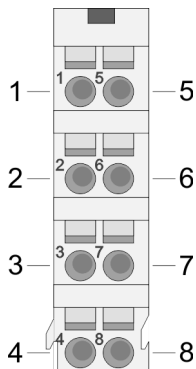

For wires with a core cross-section of 0.08mm² up to 1.5mm².

Pos.	Function	Type	Description
1	---	---	not connected
2	DC 24V	I	DC 24V for power section supply
3	0V	I	GND for power section supply
4	Sys DC 24V	I	DC 24V for electronic section supply
5	---	---	not connected
6	DC 24V	I	DC 24V for power section supply
7	0V	I	GND for power section supply
8	Sys 0V	I	GND for electronic section supply

I Input



CAUTION!

Since the power section supply is not internally protected, it is to be externally protected with a fuse, which corresponds to the maximum current. This means max. 10A is to be protected by a 10A fuse (fast) respectively by a line circuit breaker 10A characteristics Z!



The electronic power section supply is internally protected against higher voltage by fuse. The fuse is within the power module. If the fuse releases, its electronic module must be exchanged!

Fusing

- The power section supply is to be externally protected with a fuse, which corresponds to the maximum current. This means max. 10A is to be protected with a 10A fuse (fast) respectively by a line circuit breaker 10A characteristics Z!
- It is recommended to externally protect the electronic power supply for bus coupler and I/O area with a 2A fuse (fast) respectively by a line circuit breaker 2A characteristics Z.
- The electronic power supply for the I/O area of the power module 007-1AB10 should also be externally protected with a 1A fuse (fast) respectively by a line circuit breaker 1A characteristics Z.

State of the electronic power supply via LEDs

After PowerON of the System SLIO the LEDs RUN respectively MF get on so far as the sum current does not exceed 3A.

With a sum current greater than 3A the LEDs may not be activated.

Here the power module with the order number 007-1AB10 is to be placed between the peripheral modules.

Deployment of the power modules

If the 10A for the power section supply is no longer sufficient, you may use the power module from VIPA with the order number 007-1AB00. So you have also the possibility to define isolated groups.

The power module with the order number 007-1AB10 is to be used if the 3A for the electronic power supply at the backplane bus is no longer sufficient. Additionally you get an isolated group for the DC 24V power section supply with 4A.

By placing the power module 007-1AB10 at the following backplane bus modules may be placed with a sum current of max. 2A. Afterwards the power module 007-1AB10 is to be placed again. To secure the power supply, the power modules may be mixed used.

Power module 007-1AB00

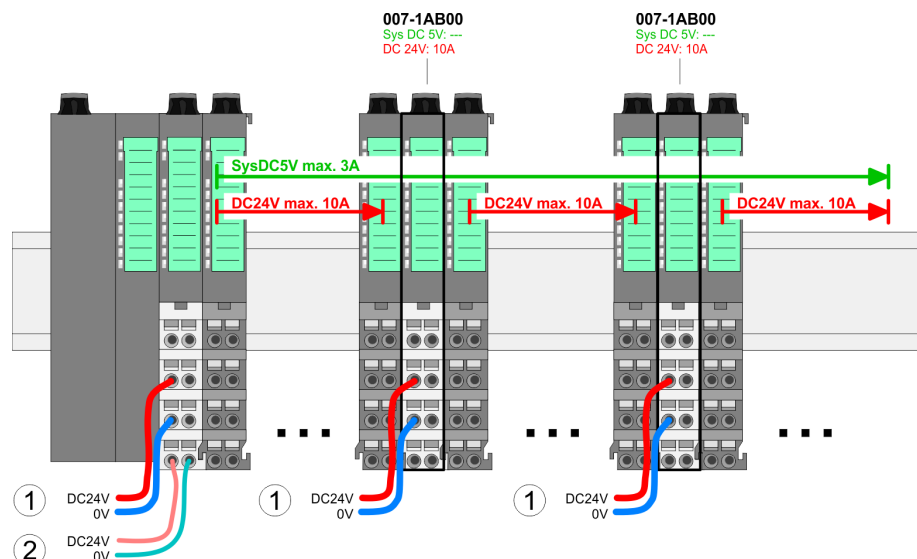

**Power module
007-1AB10**

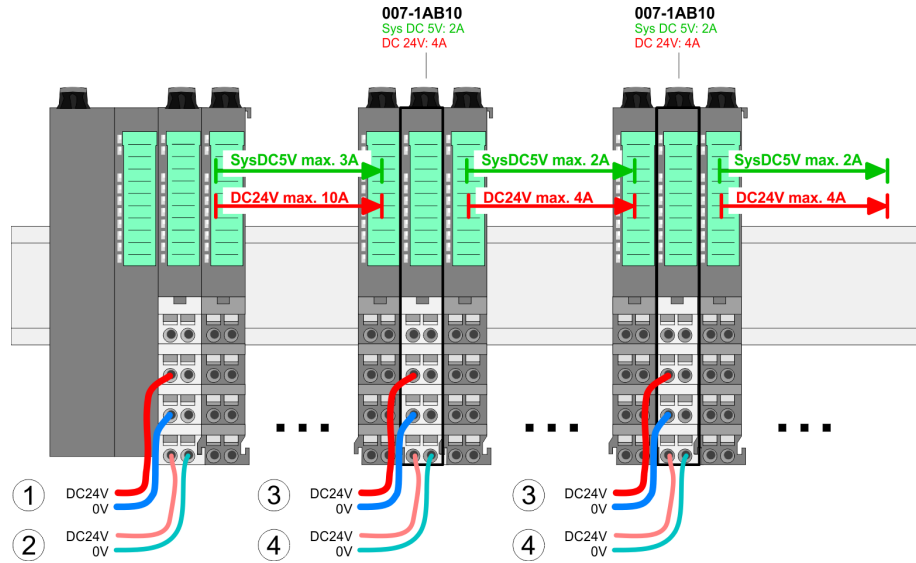

- (1) DC 24V for power section supply I/O area (max. 10A)
- (2) DC 24V for electronic power supply bus coupler and I/O area
- (3) DC 24V for power section supply I/O area (max. 4A)
- (4) DC 24V for electronic power supply I/O area

Shield attachment

To attach the shield the mounting of shield bus carriers are necessary.

The shield bus carrier (available as accessory) serves to carry the shield bus to connect cable shields.

The shield bus carrier is mounted underneath the terminal of the terminal module. With a flat mounting rail for adaption to a flat mounting rail you may remove the spacer of the shield bus carrier.

After mounting the shield bus carrier with the shield bus, the cables with the accordingly stripped cable screen may be attached and fixed by the shield clamp.

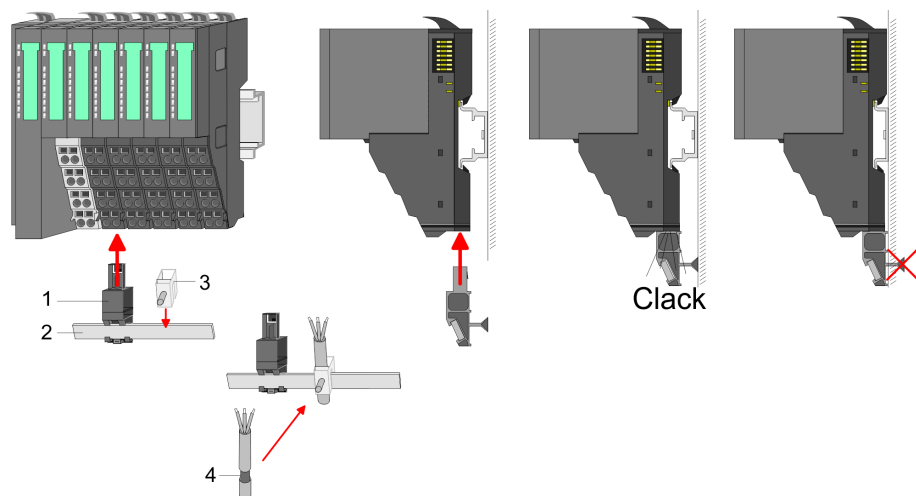

- 1 Shield bus carrier
- 2 Shield bus (10mm x 3mm)
- 3 Shield clamp
- 4 Cable shield

2.7 Trouble shooting - LEDs

General

Each module has the LEDs RUN and MF on its front side. Errors or incorrect modules may be located by means of these LEDs.

In the following illustrations flashing LEDs are marked by ☼.

Sum current of the electronic power supply exceeded

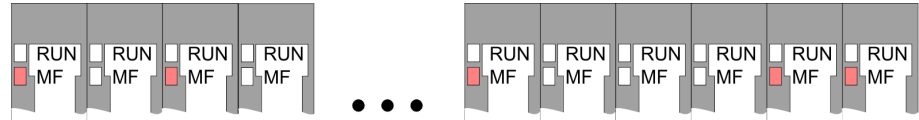

Behaviour: After PowerON the RUN LED of each module is off and the MF LED of each module is sporadically on.

Reason: The maximum current for the electronic power supply is exceeded.

Remedy: As soon as the sum current of the electronic power supply is exceeded, always place the power module 007-1AB10.

☞ *Chapter 2.6 'Wiring' on page 22.*

Error in configuration

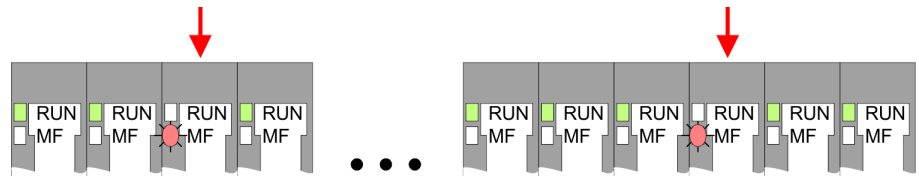

Behaviour: After PowerON the MF LED of one module respectively more modules flashes. The RUN LED remains off.

Reason: At this position a module is placed, which does not correspond to the configured module.

Remedy: Match configuration and hardware structure.

Module failure

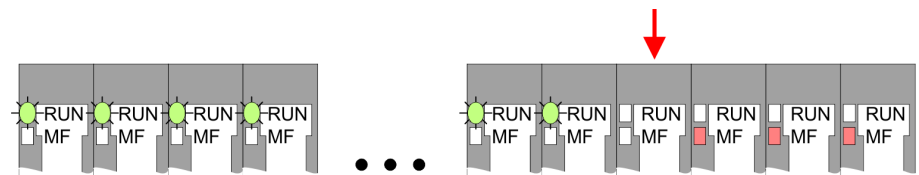

Behaviour: After PowerON all of the RUN LEDs up to the defective module are flashing. With all following modules the MF LED is on and the RUN LED is off.

Reason: The module on the right of the flashing modules is defective.

Remedy: Replace the defective module.

2.8 Installation guidelines

General

The installation guidelines contain information about the interference free deployment of a PLC system. There is the description of the ways, interference may occur in your PLC, how you can make sure the electromagnetic digestibility (EMC), and how you manage the isolation.

- What does EMC mean?** Electromagnetic digestibility (EMC) means the ability of an electrical device, to function error free in an electromagnetic environment without being interfered respectively without interfering the environment.
- The components of VIPA are developed for the deployment in industrial environments and meets high demands on the EMC. Nevertheless you should project an EMC planning before installing the components and take conceivable interference causes into account.
- Possible interference causes** Electromagnetic interferences may interfere your control via different ways:
- Electromagnetic fields (RF coupling)
 - Magnetic fields with power frequency
 - Bus system
 - Power supply
 - Protected earth conductor
- Depending on the spreading medium (lead bound or lead free) and the distance to the interference cause, interferences to your control occur by means of different coupling mechanisms.
- There are:
- galvanic coupling
 - capacitive coupling
 - inductive coupling
 - radiant coupling
- Basic rules for EMC** In the most times it is enough to take care of some elementary rules to guarantee the EMC. Please regard the following basic rules when installing your PLC.
- Take care of a correct area-wide grounding of the inactive metal parts when installing your components.
 - Install a central connection between the ground and the protected earth conductor system.
 - Connect all inactive metal extensive and impedance-low.
 - Please try not to use aluminium parts. Aluminium is easily oxidizing and is therefore less suitable for grounding.
 - When cabling, take care of the correct line routing.
 - Organize your cabling in line groups (high voltage, current supply, signal and data lines).
 - Always lay your high voltage lines and signal respectively data lines in separate channels or bundles.
 - Route the signal and data lines as near as possible beside ground areas (e.g. suspension bars, metal rails, tin cabinet).
 - Proof the correct fixing of the lead isolation.
 - Data lines must be laid isolated.
 - Analog lines must be laid isolated. When transmitting signals with small amplitudes the one sided laying of the isolation may be favourable.
 - Lay the line isolation extensively on an isolation/protected earth conductor rail directly after the cabinet entry and fix the isolation with cable clamps.
 - Make sure that the isolation/protected earth conductor rail is connected impedance-low with the cabinet.
 - Use metallic or metallised plug cases for isolated data lines.

- In special use cases you should appoint special EMC actions.
 - Consider to wire all inductivities with erase links.
 - Please consider luminescent lamps can influence signal lines.
- Create a homogeneous reference potential and ground all electrical operating supplies when possible.
 - Please take care for the targeted employment of the grounding actions. The grounding of the PLC serves for protection and functionality activity.
 - Connect installation parts and cabinets with your PLC in star topology with the isolation/protected earth conductor system. So you avoid ground loops.
 - If there are potential differences between installation parts and cabinets, lay sufficiently dimensioned potential compensation lines.

Isolation of conductors

Electrical, magnetically and electromagnetic interference fields are weakened by means of an isolation, one talks of absorption. Via the isolation rail, that is connected conductive with the rack, interference currents are shunt via cable isolation to the ground. Here you have to make sure, that the connection to the protected earth conductor is impedance-low, because otherwise the interference currents may appear as interference cause.

When isolating cables you have to regard the following:

- If possible, use only cables with isolation tangle.
- The hiding power of the isolation should be higher than 80%.
- Normally you should always lay the isolation of cables on both sides. Only by means of the both-sided connection of the isolation you achieve high quality interference suppression in the higher frequency area. Only as exception you may also lay the isolation one-sided. Then you only achieve the absorption of the lower frequencies. A one-sided isolation connection may be convenient, if:
 - the conduction of a potential compensating line is not possible.
 - analog signals (some mV respectively μA) are transferred.
 - foil isolations (static isolations) are used.
- With data lines always use metallic or metallised plugs for serial couplings. Fix the isolation of the data line at the plug rack. Do not lay the isolation on the PIN 1 of the plug bar!
- At stationary operation it is convenient to strip the insulated cable interruption free and lay it on the isolation/protected earth conductor line.
- To fix the isolation tangles use cable clamps out of metal. The clamps must clasp the isolation extensively and have well contact.
- Lay the isolation on an isolation rail directly after the entry of the cable in the cabinet. Lead the isolation further on to your PLC and don't lay it on there again!



CAUTION!

Please regard at installation!

At potential differences between the grounding points, there may be a compensation current via the isolation connected at both sides.

Remedy: Potential compensation line

2.9 General data

Conformity and approval

Conformity		
CE	2006/95/EG	Low-voltage directive
	2004/108/EG	EMC directive
Approval		
UL	UL 508	Approval for USA and Canada
others		
RoHS	2011/65/EU	Product is lead-free; Restriction of the use of certain hazardous substances in electrical and electronic equipment

Protection of persons and device protection

Type of protection	-	IP20
Electrical isolation		
to the field bus	-	electrically isolated
to the process level	-	electrically isolated
Insulation resistance		-
Insulation voltage to reference earth		
Inputs / outputs	-	AC / DC 50V, test voltage AC 500V
Protective measures	-	against short circuit

Environmental conditions to EN 61131-2

Climatic		
Storage / transport	EN 60068-2-14	-25...+70°C
Operation		
Horizontal installation	EN 61131-2	0...+60°C
Vertical installation	EN 61131-2	0...+60°C
Air humidity	EN 60068-2-30	RH1 (without condensation, rel. humidity 10... 95%)
Pollution	EN 61131-2	Degree of pollution 2
Mechanical		
Oscillation	EN 60068-2-6	1g, 9Hz ... 150Hz
Shock	EN 60068-2-27	15g, 11ms

General data

Mounting conditions

Mounting place	-	In the control cabinet
Mounting position	-	Horizontal and vertical

EMC	Standard	Comment
Emitted interference	EN 61000-6-4	Class A (Industrial area)
Noise immunity zone B	EN 61000-6-2	Industrial area
	EN 61000-4-2	ESD 8kV at air discharge (degree of severity 3), 4kV at contact discharge (degree of severity 2)
	EN 61000-4-3	HF irradiation (casing) 80MHz ... 1000MHz, 10V/m, 80% AM (1kHz) 1.4GHz ... 2.0GHz, 3V/m, 80% AM (1kHz) 2GHz ... 2.7GHz, 1V/m, 80% AM (1kHz)
	EN 61000-4-6	HF conducted 150kHz ... 80MHz, 10V, 80% AM (1kHz)
	EN 61000-4-4	Burst, degree of severity 3
	EN 61000-4-5	Surge, installation class 3 *

*) Due to the high-energetic single pulses with Surge an appropriate external protective circuit with lightning protection elements like conductors for lightning and overvoltage is necessary.

3 Hardware description

3.1 Properties

Features

The interface module 053-1DN00 is a head station for the System SLIO with an DeviceNet interface. With the DeviceNet interface the input data can be read and output data written, which parameterization system, as well as updates be accomplished.

- Group 2 only Device
 - employs the predefined connection set
- Poll only Device
 - no BIT STROBE mode support
 - no CHANGE OF STATE support
 - Profile Generic Device
- Configuration via DIP switch
 - DeviceNet address (0 ... 63)
 - Transfer rate for the DeviceNet coupler
- Supports all baud transfer rates: 125, 250 and 500kbit/s
- Configuration of up to 64 peripheral modules
- max. 255 byte in-/output data
- Configuration of the periphery modules is made by a *DeviceNet manager* e.g. RsNetWorx from Allen-Bradley. For parameterization and for the access to the diagnostics data the data type SHORT_STRING is used. Please consider that your configuration tool supports this type of data.

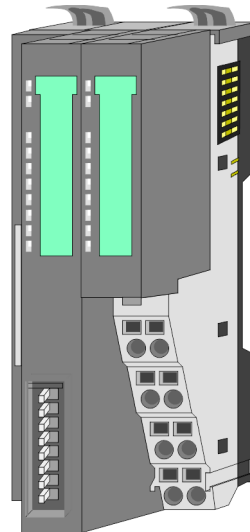

Ordering data

Type	Order number	Description
IM 053DN	053-1DN00	DeviceNet coupler for System SLIO

3.2 Structure

053-1DN00

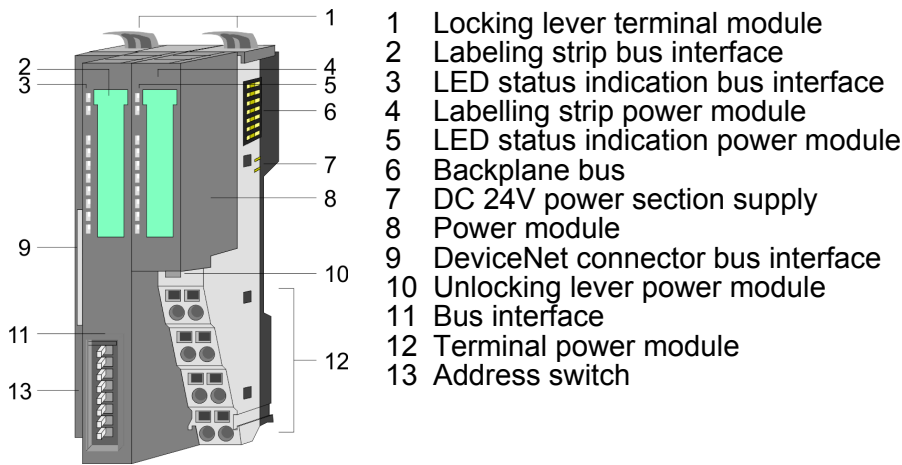

3.2.1 Interfaces

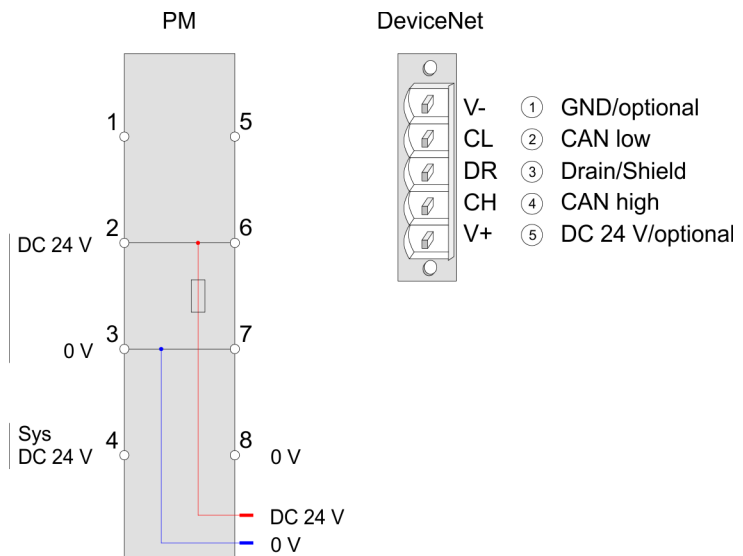

CAUTION!
 Bus interface and power module of the bus coupler may not be separated!
 Here you may only exchange the electronic module!

PM - Power module

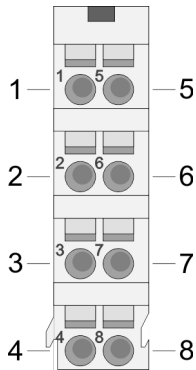

For wires with a core cross-section of 0.08mm² up to 1.5mm².

Pos.	Function	Type	Description
1	---	---	not connected
2	DC 24V	I	DC 24V for power section supply
3	0V	I	GND for power section supply
4	Sys DC 24V	I	DC 24V for electronic section supply
5	---	---	not connected
6	DC 24V	I	DC 24V for power section supply
7	0V	I	GND for power section supply
8	Sys 0V	I	GND for electronic section supply

I Input

Interface for DeviceNet communication

- The DeviceNet connection is provided by a 5pin open style connector.
- The pin assignment is imprinted on the front of the module.
- The shield is to be connected to pin 3 (DR) and grounded at one suited place within its network.
- You receive a suited plug from VIPA with the order number VIPA 000-0DN00.
- Members of the bus may optionally be supplied by an external DC 24V power supply.
- The bus is to be terminated at both of its ends with 120Ω.

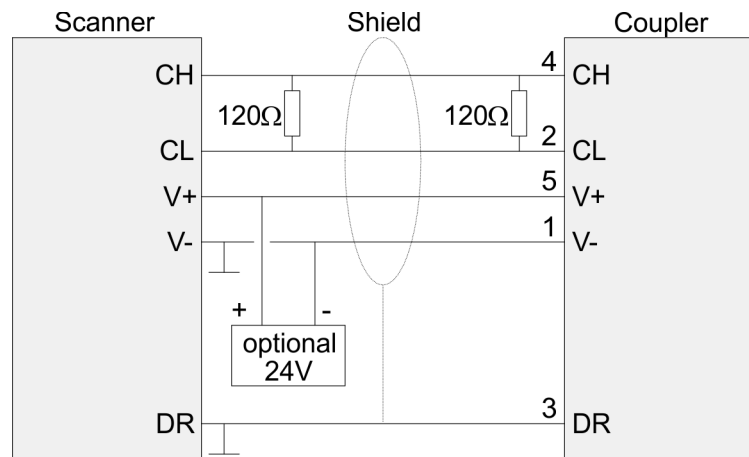

3.2.2 Address switch

Overview

The address switch serves for the following settings:

- Transfer rate
- DeviceNet address
- Automatic module configuration
- Update mode for firmware update



Changes of the transfer rate respectively of the DeviceNet address were only recognized after PowerON or an automatic reset. Changes during the normal operation are not recognized!

Settings

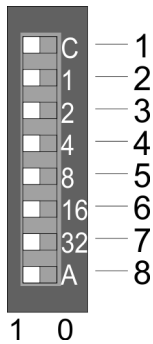

Transfer rate

No.	Description	Example Setting	
1	Configuration	1	Transfer rate: 250kbit/s
2	Transfer rate 125kbit/s	0	
3	Transfer rate 250kbit/s	1	
4	Transfer rate 500kbit/s	0	
5	-	-	
6	-	-	
7	-	-	
8	-	-	

DeviceNet address

No.	Description	Example Setting	
1	Configuration	0	1+2+32=35 Address: 35
2	2 ⁰ = 1	1	
3	2 ¹ = 2	1	
4	2 ² = 4	0	
5	2 ³ = 8	0	
6	2 ⁴ = 16	0	
7	2 ⁵ = 32	1	
8	Auto configuration	0/1	

Auto configuration

- On start-up with *Auto configuration* = 1 the current module configuration is always kept without acknowledge from the engineering tool.
- With *Auto configuration* = 0 the current module configuration is fix stored.

Update mode for firmware update

No.	Description	Setting
1	Configuration	1
2	-	0
3	-	0
4	-	0
5	-	0
6	-	0
7	Update mode	1
8	-	-

3.2.3 LEDs

LEDs power module

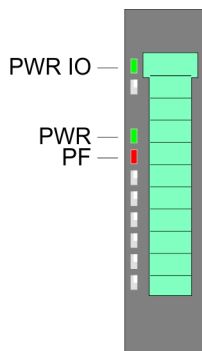

PWR IO	PWR	PF	Description
green ■	green ■	red ■	
●	X	○	Power section supply OK
●	●	○	Electronic section supply OK
X	X	●	Fuse electronic section supply defective
on: ● off: ○ not relevant: X			

Status indication bus interface

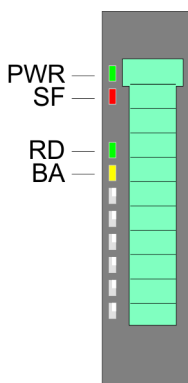

LED	Description
PWR ● ■ green	Bus interface is power supplied
SF ● ■ red	Error on DeviceNet or System SLIO bus
RD ● ■ green	Status System SLIO bus
BA ● ■ yellow	Status DeviceNet
an: ●	
🔗 Chapter 4.4 'Status indication - Diagnostics' on page 46	

3.3 Technical Data

Order no.	053-1DN00
Type	IM 053DN
Module ID	-
Technical data power supply	
Power supply (rated value)	DC 24 V
Power supply (permitted range)	DC 20.4...28.8 V
Reverse polarity protection	✓
Current consumption (no-load operation)	90 mA
Current consumption (rated value)	0.95 A
Inrush current	3.9 A
I^2t	0.14 A ² s
Max. current drain at backplane bus	3 A
Max. current drain load supply	10 A
Power loss	3 W
Status information, alarms, diagnostics	
Status display	yes
Interrupts	-
Process alarm	-
Diagnostic interrupt	-
Diagnostic functions	-
Diagnostics information read-out	possible
Supply voltage display	green LED
Service Indicator	-
Group error display	red SF LED
Channel error display	none
Hardware configuration	
Racks, max.	1
Modules per rack, max.	64
Number of digital modules, max.	64
Number of analog modules, max.	64
Communication	
Fieldbus	DeviceNet
Type of interface	CAN
Connector	5-pin Open Style Connector
Topology	Linear bus with bus termination at both ends
Electrically isolated	✓

Order no.	053-1DN00
Number of participants, max.	64
Node addresses	0 - 63
Transmission speed, min.	125 kbit/s
Transmission speed, max.	500 kbit/s
Address range inputs, max.	256 Byte
Address range outputs, max.	256 Byte
Number of TxPDOs, max.	-
Number of RxPDOs, max.	-
Housing	
Material	PPE / PPE GF10
Mounting	Profile rail 35 mm
Mechanical data	
Dimensions (WxHxD)	48.5 mm x 109 mm x 76.5 mm
Weight	155 g
Environmental conditions	
Operating temperature	0 °C to 60 °C
Storage temperature	-25 °C to 70 °C
Certifications	
UL508 certification	yes

4 Deployment

4.1 Basics DeviceNet

General

DeviceNet is an open low-end network that is based upon the physical properties of CAN bus. The bus is also used to supply the devices with the required DC 24V power. You can use DeviceNet to install direct connections between your control system and simple industrial devices like sensors and switches as well as technologically advanced devices like frequency converters and barcode readers. Direct interfacing improves communications between the different devices and provides important diagnostic facilities at the device level.

DeviceNet

- DeviceNet is an open device net standard that satisfies the user profile for industrial real-time system applications.
- The DeviceNet protocol has an open specification that is the property of and administered by the independent vendor organization "Open DeviceNet Vendor Association" ODVA.
- This is where standardized device profiles are created to provide compatibility and exchangeability on logical level for simple devices of the same type.
- In contrast to the classical source-destination model, DeviceNet uses a modern producer/consumer model that requires data packets with identifier fields for the identification of the data.
- This approach caters for multiple priority levels, more efficient transfers of I/O data and multiple consumers for the data.
- A device that has data to send *produces* the data on the network together with an identifier. All devices requiring data listen for messages. When devices recognize a suitable identifier, they act and *consume* the respective data.
- DeviceNet carries two types of messages:
 - *I/O messages*
Messages that are subject to critical timing constraints and that are contain data for control purposes that can be exchanged by means of single or multiple connections and that employ identifiers with a high priority.
 - *Explicit messages*
These are used to establish multi-purpose point-to-point communication paths between two devices, which are used for the configuration of network couplers and for diagnostics purposes. These functions usually employ identifiers of a low priority.
- Messages that are longer than 8byte are subject to the fragmentation service. A set of rules for master/slave, peer-to-peer- and multi-master connections is also available.

Communication medium

- DeviceNet employs a screened five-core cable as data communication medium. DeviceNet uses voltage differences and for this reason it exhibits less sensitivity to interference than a voltage or current based interface.
- Signals and power supply conductors are included in the same network cable. It is therefore possible to connect devices that obtain the operating voltage via the network as well as devices with an integrated power supply. Furthermore it is possible to connect redundant power supplies to the network that guarantees the power supply when required.

- DeviceNet employs a master line/tap line topology with up to 64 network nodes. The maximum distance is either 500m at a rate of 125kbit/s, 250m at a rate of 250kbit/s or 100m at a rate of 500kbit/s.
- The length of the tap lines can be up to 6m while the total length of all tap lines depends on the transfer rate.
- Network nodes can be removed from or inserted into the network without interruption of the network operation. New and failed stations are detected automatically.

Bus access method

- DeviceNet operates according to the Carrier-Sense Multiple Access (CSMA) principle, i.e. every station on the network may access the bus when it is not occupied (random access).
- The exchange of messages is message orientated and not station orientated. Each message is provided with a unique and prioritizing identifier. At any time only one station is able to occupy the bus with its messages.
- The DeviceNet bus access control is subject to non-destructive, bit-wise arbitration. In this case non-destructive means that the successful station participating in the arbitration doesn't need to re-send its message. The most important station is selected automatically when multiple stations access the bus simultaneously. If a station that is ready to send recognizes that the bus is occupied, its send request is delayed until the current transfer has been completed.

Addressing

- All stations on the bus must be uniquely identified by means of an ID address.
- Every DeviceNet device has addressing facilities.

EDS file:

- From VIPA there are EDS (Electronic Data Sheet) files for the DeviceNet coupler available. These files may either be found on the supplied storage media or at the download area of www.vipa.com
- Please install the EDS file you require in your configuration tool. Details on the installation of the EDS file are available from the manual supplied with your configuration tool.

4.2 Accessing the System SLIO

Overview

In the following you will find the description of accessing I/O area, parameter data and diagnostics data of the System SLIO via DeviceNet:

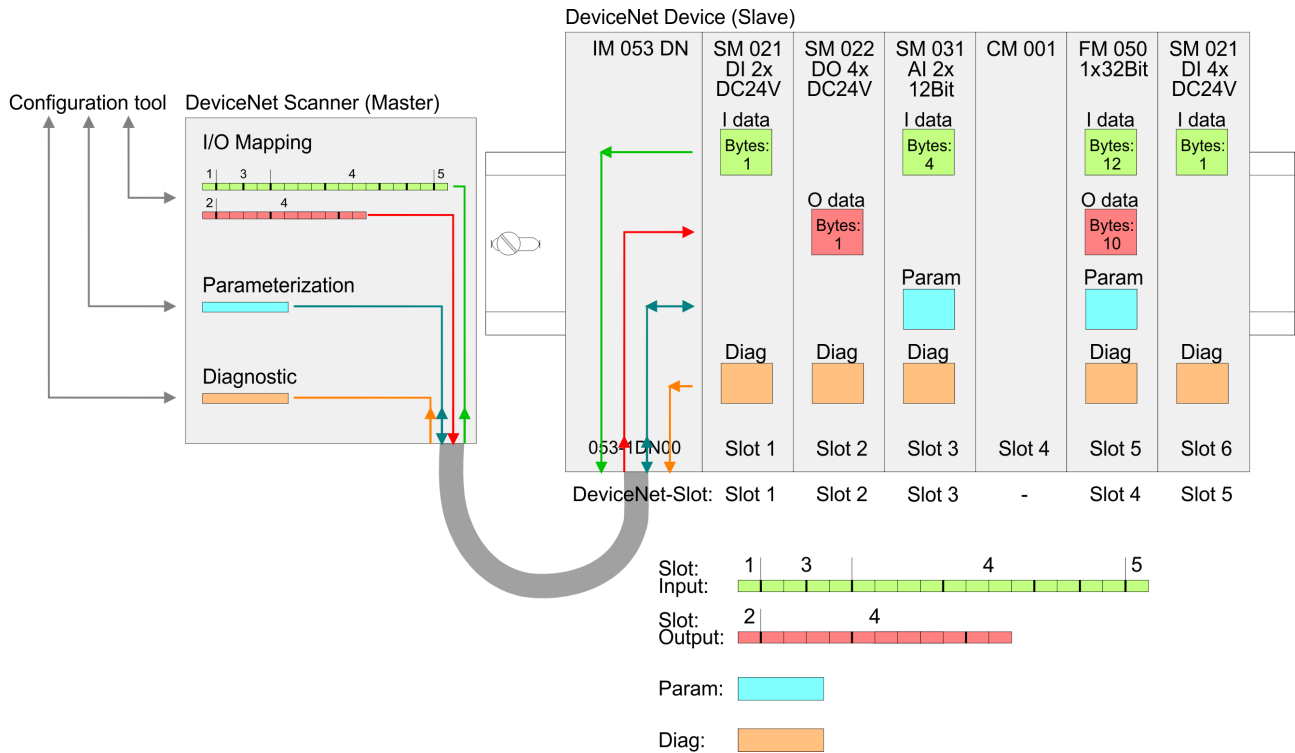

Information concerning the allocation of these areas may be found in the description of the corresponding System SLIO module.



Please consider the System SLIO power and clamp modules do not have any module ID. These may not be recognized by the DeviceNet coupler and so are not listed and considered during slot allocation. Further within DeviceNet the slots are designated as DeviceNet-Slot. The counting always begins with 1.

Note to the assignment of the module configuration

If you do not use a DeviceNet scanner from Allen-Bradley as long as you change the System SLIO module configuration, you should activate the auto configuration. To activate the Auto configuration switch the DIP switch A of the address switch to "1" before switching on the power supply. To store the module configuration, switch the DIP switch A of the address switch to "0".

When used with a DeviceNet scanner from Allen-Bradley if the configuration of the modules has been changed, the coupler must be advised to take the new configuration. For this one of the following actions must be executed otherwise an error is reported:

- Reading the device name of a installed module (Class Code 101 ... 164, Instance 1)
- Reading respectively writing of a parameter character of a installed module (Class Code 101 ... 164, Instance 20)

EDS file

From VIPA you may receive an appropriate EDS file (**Electronic Data Sheet**) for your DeviceNet coupler, which depends on your configuration (number of modules). These files may either be found on the supplied storage media or at the download area of www.vipa.com. Please install the EDS file you require in your configuration tool. Details on the installation of the EDS file are available from the manual supplied with your configuration tool.

EDS file name	Usage
Maximum number of diagnostics data - slow	
VIPA-053-1DN00_16-ext	- supports maximally 16 System SLIO modules
VIPA-053-1DN00_32-ext	- supports maximally 32 System SLIO modules
VIPA-053-1DN00_64-ext	- supports maximally 64 System SLIO modules
Reduced diagnostics - deviceName, parameter, diagnostics - fast	
VIPA-053-1DN00_16	- supports maximally 16 System SLIO modules
VIPA-053-1DN00_32	- supports maximally 32 System SLIO modules
VIPA-053-1DN00_64	- supports maximally 64 System SLIO modules

4.2.1 Accessing the I/O area

- The DeviceNet coupler determines automatically the modules on the System SLIO bus and generates from this the number of input and output bytes.
- During the configuration of the DeviceNet scanner the corresponding overall length of the input and the output bytes is to be preset. Information concerning the I/O allocation of a module may be found in the corresponding manual.
- The position (offset) of the input respectively output bytes within the input respectively output data results from the order of the modules (DeviceNet-Slot 1 ... 64).
- By means of the base address, which is to be preset in the DeviceNet scanner for the bus coupler and the offset you may access the input or output data of a module.
- During operation the DeviceNet coupler cyclically reads the input data of the peripheral modules and serves for the last state of these data for the DeviceNet scanner.
- Output data, which the DeviceNet coupler has received from the DeviceNet scanner, were directly transferred to the modules, as soon as they were received.

DeviceNet scanner (master) configuration

1. ▶ Turn off the power supply of the DeviceNet coupler and preset the transfer rate and the DeviceNet address. ↪ *Chapter 4.3 'Transfer rate and DeviceNet address' on page 44*
2. ▶ Start the configuration tool of your DeviceNet scanner.
3. ▶ Set the DeviceNet scanner to connection type "POLL IO".
4. ▶ Enter the number of input and output data:
 - Number input data: Produced connection size
 - Number output data: Consumed connection size
5. ▶ Enter a base address for the input and output data (mapping).

- 6. ▶ Activate the System SLIO DeviceNet coupler IM 053DN in the scan list.
- 7. ▶ Start the DeviceNet scanner.
 - ⇒ When the DeviceNet scanner has been configured, the input and output modules are accessible via the configured addresses.

4.2.2 Accessing parameter data

The System SLIO modules may also be parameterized by the configuration tool. For this your DeviceNet couple must be connected active at the bus. For parameterization and for the access to the diagnostics data the data type SHORT_STRING is used. Please consider that your DeviceNet manager supports this type of data. In your configuration tool you may parameterize your module by means of a character string. You also may transfer the current parameters from the module into your configuration tool to adapt them and write them back to the module.

Rules for the parameterization

- Each DeviceNet-Slot is separately be parameterized with a character string.
- Within the character string each parameter consists of a Type with attached Value.
- The parameters themselves are to be separated by a blank.
- There are only parameter strings with lower case supported.

Depending on the type hexadecimal, decimal or binary values may be preset:

Type	Meaning	Value as	Range of values	Character string	Example number
x	1byte	hexadecimal	00h ... FFh	<i>xhh</i>	xA2
2x	2byte	hexadecimal	0000h ... FFFFh	<i>2xhhhh</i>	2x7FFF
4x	4Byte	hexadecimal	00000000h ... FFFFFFFFh	<i>4xhhhhhhhh</i>	4x7FFF80C0
+	1byte	decimal positive	0 ... 255	<i>+ddd</i>	+255
2+	2byte	decimal positive	0 ... 65535	<i>2+dddd</i>	2+65535
4+	4byte	decimal positive	0 ... 4294967295	<i>4+ddddddddd</i>	4+4294967295
-	1byte	decimal negative	-128 ... -1	<i>-ddd</i>	-128
2-	2byte	decimal negative	-32768 ... -1	<i>2-ddddd</i>	2-32768
4-	4byte	decimal negative	-2147483648 ... -1	<i>4-ddddddd</i>	4-2147483648
b	1byte	binary	00000000 ... 11111111	<i>bbbbbbbbb</i>	b10100101

Example

The analog module 031-1BB90 has 18byte parameter data. For the parameterization with default values this results in the following string:
 x00 x00 x00 x00 x00 x02 xC1 x02 2x7FFF 2x8000 xC1 x02 2x7FFF 2x8000



As soon as the parameter data do not fit to the sequence of the modules on the System SLIO bus, the DeviceNet coupler goes to an error state and signals this with its status LEDs.

Due to the system, modules which are not yet parameterized are supplied with their default parameters as soon as you start a read access from your configuration tool.

4.2.3 Accessing diagnostics data

The DeviceNet coupler only supports passive diagnostics. This means for the diagnostics that there is no alarm activation on module side necessary. You have to request the diagnostics. For this select in your configuration tool the diagnostics data of the corresponding DeviceNet-Slot. Then you get the diagnostics data of this module as byte sequence. Information concerning structure of the diagnostics data may be found in the description of the corresponding System SLIO module.

Accessing firmware information

If this is supported by your configuration tool, via the corresponding DeviceNet-Slot you may get more information about the current version of your System SLIO.

System SLIO DeviceNet coupler - Class Code: 100 (64h)

No.	Name	Information	Format	Example
1	DeviceName	Name of the device	String	VIPA 053-1DN00
2	HwVersion	Hardware version	String	02
3	SwVersion	Software version	String	V101
4	SerialNumber	Serial number	Unsigned32, String	00000205
5	FpgaVersion	FPGA version	Unsigned16, String	V208
6	MxFile	Mx file	String	MX000053.101
7	ProductVersion	Product version	String	01V01.00
8	OrderCode	Order no.	String	053-1DN00

System SLIO module - Class Code: Slot 1: 101 (65h), Slot 2: 102 (66h), ... , Slot 64: 164 (A4h)

No.	Name	Information	Format	Example
1	DeviceName	Name of the device	String	VIPA 032-1BD40
2	HwVersion	Hardware version	String	21
3	SwVersion	Software version	String	V202
4	SerialNumber	Serial number	Unsigned32, String	00001143
5	FpgaVersion	FPGA version	Unsigned16, String	V208
6	MxFile	Mx file	String	MX000028.130
7	ProductVersion	Product version	String	01V31.001
8	OrderCode	Order no.	String	032-1BD40
20	Parameter	Parameter data	String	x00 x00 x31 x31 x31 x31
21	Diagnostics	Diagnostics data	String	x00 x15 x00 x00 x73 x08 x04 x00 x00 x00 x00 x00 x00 x00 x00 4x000020EB

4.3 Transfer rate and DeviceNet address

Overview

With PowerOFF there is the possibility to specify the *Transfer rate* respectively the *DeviceNet-Address* and then to activate these with PowerON in the module.



Changes of the transfer rate respectively of the DeviceNet address were only recognized after PowerON or an automatic reset. Changes during the normal operation are not recognized!

4.3.1 Setting the transfer rate

Proceeding

Every station on the bus communicates with the same transfer rate. The setting of the transfer rate happens with the following proceeding:

1. ➤ Turn off the power supply.
2. ➤ Set switch 1 to "1" (Configuration).
3. ➤ Preset the transfer rate with switch 2 ... 4.

4. Switch on the power supply.

⇒ The preset transfer rate is stored in the EEPROM. Your DeviceNet coupler now uses this transfer rate.

LED indication (RD, SF):

With a successful storage the RD LED (green) gets on.
With a wrong setting of the transfer rate the SF LED (red) lights up.

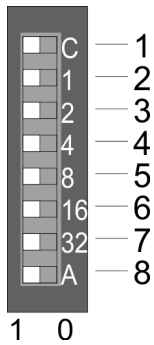

Pos.	Description	Example	
		Setting	Description
1	Configuration	1	Transfer rate: 250kbit/s
2	Transfer rate 125kbit/s	0	
3	Transfer rate 250kbit/s	1	
4	Transfer rate 500kbit/s	0	
5	-	-	
6	-	-	
7	-	-	
8	not used	-	

4.3.2 Setting the DeviceNet address

Proceeding

All stations on the bus must be uniquely identified by means of an ID address. The setting of the DeviceNet address happens with the following proceeding:

- 1.** Turn off the power supply.
- 2.** Set switch 1 to "0" (Address).
- 3.** Preset the DeviceNet address with switch 2 ... 7 as a binary value.
- 4.** Switch on the power supply.

⇒ The preset DeviceNet address is stored in the RAM.

LED indication (SF):

With a wrong or already used address after PowerON the SF LED (red) lights up.



Please regard each DeviceNet address is taken once at the bus between a number of 0 ... 63!

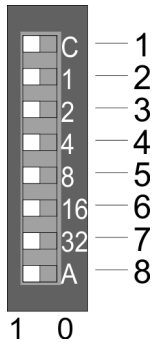

Pos.	Description	Example	
		Setting	Description
1	Configuration	0	1+2+32=35 Address: 35
2	2 ⁰ = 1	1	
3	2 ¹ = 2	1	
4	2 ² = 4	0	
5	2 ³ = 8	0	
6	2 ⁴ = 16	0	
7	2 ⁵ = 32	1	
8	Auto configuration	-	

Auto configuration - On start-up with *Auto configuration* = 1 the current module configuration is always kept without acknowledge from the engineering tool.
 With *Auto configuration* = 0 the current module configuration is fix stored.

4.4 Status indication - Diagnostics

General

The LEDs, which are installed to display the status, allow extensive diagnostics during the PowerON-procedure as well as during operation. The result of the diagnostics is determined by the combination of the different LEDs and the current operating mode. Here the RD LED corresponds to the System SLIO backplane bus and the BA LED to the DeviceNet bus.

LED indication

SF	RD	BA	Meaning
●	○	○	Setting on the address switch is not valid
○	●	○	The transfer rate was successfully stored
B	B	B	Firmware update running
●	●	●	Firmware update finished successfully
E	●	●	Firmware update finished with error <ul style="list-style-type: none"> ■ Error in EDS file ■ Transfer error ■ Error in flash
X	X	○	Field bus is offline <ul style="list-style-type: none"> ■ no DC 24V on the connector ■ no further station on the field bus
X	X	B	Field bus ready <ul style="list-style-type: none"> ■ no connection established
X	X	●	Field bus connected

SF	RD	BA	Meaning
•	X	○	Error field bus <ul style="list-style-type: none"> ■ Field bus address just exists ■ Communication error on the field bus
•	X	B	Inactivity <ul style="list-style-type: none"> ■ connection disconnected due to inactivity
X	B	X	System SLIO bus ready, outputs inactive
X	•	X	System SLIO bus active
•	E	X	Error on access the System SLIO bus
E	E	X	Configuration error System SLIO bus <ul style="list-style-type: none"> ■ The number of real modules at the bus differs to the configured modules. ■ The module type of at least one module differs to the type of the configured module.
B	E	E	Device error / internal error - please contact the VIPA support!

on: • | off: ○ | not relevant: X

Blinking code *B* at a period duration of 1s: ○○●●

Blinking code *E* (Error) at a period duration of 2s: ○○○○●○●